

PEB Services B.V.
 Stephensonstraat 30, PO Box 186
 2700 AD Zoetermeer, The Netherlands
 Telephone 31-(0)79-3417 714
 Telefax 31-(0)79-3313 502
Services@peb.nl



HOTTAP SPECIFICATION SHEET

Customer: _____	Date of operation: _____
Customer ref.: _____	Contact person: _____
Contact person: _____	During operation: _____
Telephone nr.: _____	Telephone nr.: _____
Handled by: _____	Location of operation: _____
Date: _____	P.E.B. ref.: _____

HOTTAP SPECIFICATIONS

Hottap nom. size: _____
 Hottap act. size: _____
 Quantity: _____
 Product: _____
 Aggressive? _____
 Pressure/Temp.: _____ kg/cm² _____ C^o

PARTICULARS OF AVAILABLE EQUIPMENT

Outside diameter: _____
 Wall thickness: _____
 Internal diameter: _____
 Mat. specification: _____
 Type of valve: _____
 Flange connection: _____

Hottap on a: pipeline/tankwall
 blindflang
 valve gate
 Position of the machine: horizontal vertical

Coating (other than paint)
 Location: intern. extern.
 Thickness: _____
 Specification: _____

HOTTAP SPECIFICATIONS

A=height stub _____ mm
 B=face to face valve _____ mm
 C=total height _____ mm
 D=intern. diam. Valve _____ mm
 E=distance flange/gate _____ mm
 F=restriction of gate _____ mm
 G=internal diam. stub _____ mm
 H=available space _____ mm
 K=height from ground level _____ mm

Scaffolding present no yes
 Crane present no yes min. _____ kg
 Compressed air no yes min. 3m/min. 6 bar
 Gaskets and bolting PEB klant

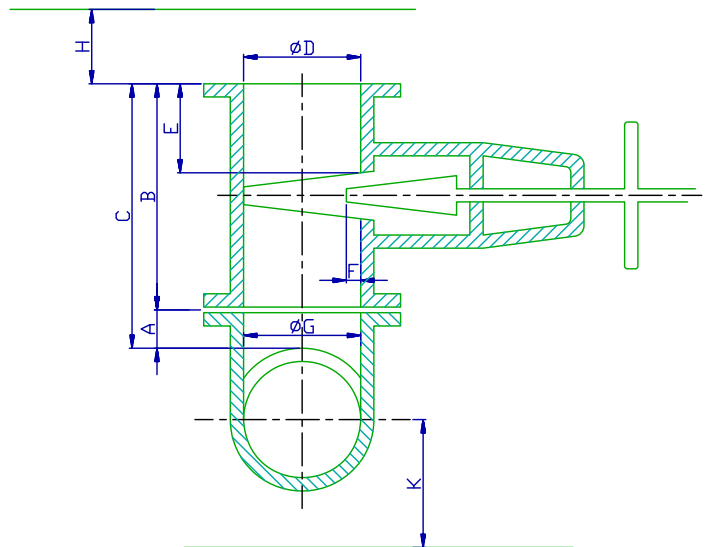

Remarks _____

FOR ACCEPTANCE OF OPERATION

Coupon submitted: <input type="checkbox"/> yes <input type="checkbox"/> no	Order: _____
Waiting time: _____ uur	Reason waiting time: _____
Name engineer: _____	Name customer: _____

Signature: _____ Signature: _____